

Reference Diagrams

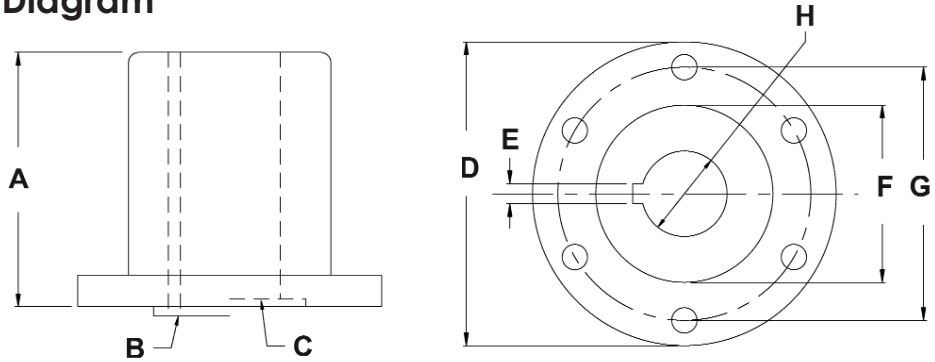

Coupler Reference Diagram

- A - Overall Length
- B - Male Pilot (M type)
- C - Female Pilot (F type)
- D - Flange Diameter
- E - Keyway Width
- F - Pilot Diameter
- G - Bolt Circle Diameter
- H - Shaft Diameter



Please circle which type of coupler you are looking for below:

- Reverse Taper
- Solid Split
- Standard Taper

Company: _____

Phone#: _____

Fax#: _____

Contact: _____

Overall Length: _____

Pilot: **M or F**

Pilot Depth or Height: _____

Flange Diameter: _____

Keyway Width: _____

Pilot Diameter: _____

Bolt Circle: _____

Number of Bolts: _____

Shaft Diameter: _____

Small End Taper:
(Taper Couplers Only) _____

Buck Algonquin specializes in custom castings. If you would like us to quote you on a special coupler or you only have the dimensions of the existing coupler you are trying to match please fill in the blanks with the dimensions you are looking for and fax it back to us at (410) 643-7777 or simply email it to us at sales@buckalgonquin.com. We will do our best to find a coupler that we currently have in stock that best matches the dimensions given or quote you on a custom coupler. If you have any questions or concerns please contact our knowledgeable sales staff to help guide you through the process.

Fittings Size Chart Male NPT Thread Sizes

