

Hydrasearch

COMMERCIAL



Table of Contents

History	2	Valves	26
Hydrasearch In The Making	2	Cast Iron Threaded Foot Valves.....	26
Education	4	Spring Loaded Check Valves	27
Hydrasearch Capabilities.....	4	Gate Valves.....	28
Industry Terms	6	Domestic Full Port Ball Valves	28
Industry Cross Reference	7	Wye Valve	29
Hydrasearch Naming Convention	7	Global Angle Valves.....	29
Warranty Policy.....	8	Nozzles	30
Proposition 65 Warning	8	Industrial Wash Down Nozzles.....	30
Return Policy.....	9	Fog Nozzles.....	30
Air Pipe Heads.....	10	USCG Approved AFFF/Water Nozzles.....	31
Air Pipe Heads (<i>aluminum</i>)	10	USCG Approved Fog Nozzles	31
Air Pipe Heads (<i>steel</i>)	12	International Shore Connections....	32
Inverted Vent Check Valves	14	100R5 Hydraulic Fittings.....	33
PM1 Series Full Float	14	AQ-22 Marine Rudders.....	34
PM1 Series Half Float	16	References	36
Deck Drains	18	Steel Flange Dimension.....	36
Suction Bellmouths	19	Metric Flanges and Dimensions.....	37
Sounding Tubes	20	Fraction to Decimal Conversions	38
Pipe Caps	21		
Strainers	22		
Suction Strainer Box.....	22		
Round Hole Strainer	23		
Arctic Steel Strainers	24		

Hydrasearch In The Making

Hydrasearch began in the early 1960s from a growing demand for more “think tank” factories near Washington, D.C. to support our national defense. From hydraulic research and design to our most recent acquisition of venting solutions, our product offering has been an expanding effort to fulfill the needs of our customers. We are proud to manufacture a trusted product offering for over 60 years.



1962

Hydrasearch is founded by Willard G. Triest in Annapolis, MD, specializing in the research and manufacturing of hydraulic valves and component devices.



1970s

Hydrasearch primary focus during the 70s was designing hydraulic control systems for the government and fueling at sea equipment for the US Navy.



1994

Hydrasearch relocated to Stevensville, Maryland. The new 30,000 square foot facility allowed Hydrasearch to merge its inventory, machining, testing and offices under one roof.

1960s

Hydrasearch is acquired by Dixon Valve & Coupling Company, a leading innovator in the hose coupling industry for over 100 years.



1980s

Hydrasearch developed and tested a new line of hose and fittings that solved many ongoing leakage problems. This led to Hydrasearch being a Naval Sea Systems Command for Qualified Product Listing (QPL) vendor in 1989.



1995

Hydrasearch purchased Technical Products. This acquisition established Hydrasearch as an even larger supplier to the military market.



Hydrasearch In The Making



1998

Hydrasearch aquired the field attachment hose and fitting product line from Deutsch Metal Components of Gardena, CA. The product line consists of rubber hose assemblies and components.



2010

Hydrasearch merged with Buck Algonquin under the name Hydrasearch Company, Inc. This merger brought an expansion into the maritime market.



2016

Hydrasearch acquired Arctic Steel Water Strainers and Pro-Mar Maritime Venting Solutions. These acquisitions expanded our product offering into the workboat industry.

2000

Hydrasearch received its first ISO 9001 certification. The registration is recognized as a measure of a supplier's quality assurance process.

ISO 9001:2000



2016

Hydrasearch relocated to its current facility within the same business park in Stevensville, MD. The facility is 65,000 square feet allowing for increased efficiency and production.



Hydrasearch Capabilities



Hydrasearch Company, LLC (Stevensville, MD) has been an established leader in manufacturing for the maritime industry since 1962. We specialize in manufacturing venting solutions and commercial marine hardware for the workboat industry. We are proud to say that many of our products are ABS approved. Our mission is to provide quality products and excellent customer service.

Advantages of buying Hydrasearch

ABS Approved

Many of our product offerings are ABS approved.

Quality Assurance

Hydrasearch maintains a mature quality control process that puts us ahead of the competition in the marine hardware industry. Our Quality Management System is driven by our listing as a preferred vendor (QPL) to the US Navy. To ensure our quality, we are continuously improving our equipment, processes and training.

In addition, we are a certified International Standards of Operation (ISO 9001: 2015) company and have a type certification to the the Royal Institution of Naval Architects (RINA).

Engineering Support

Hydrasearch has an extensive support system that include the following programs:

- 3D printing
- Coordinate Measuring Machine (CMM)
- Finite element analysis
- Flow simulation
- Fully staffed quality department
- In house chemical analysis for metals
- Modern machine shop
- Multiple CAD software support
- Rapid prototyping
- Solidworks capabilities

Hydrasearch Capabilities

Workboat Applications:

- Barges
- Cargo vessels
- Defense vessels
- Offshore oil rigs
- Offshore support vessels (OSV)
- Passenger vessel operations
- Tugs and towing



Industry Terms

AFFF

Aqueous Film Forming Foam (AFFF) is a type of fire suppressant agent

Anodize

A type of coating with a protective oxide layer by an electrolytic process in which the metal forms the anode

ANSI

American National Standards Institute (ANSI) oversees the development of voluntary consensus standards

AQ-22

A corrosive resistant stainless steel material which has increased resistance to crevice corrosion compared to Stainless Steel (316) and Monel (400) material

Butt weld

A welding technique used to join two components together without overlapping the ends

Cadmium (CAD) plating

A type of coating process that offers technical benefits such as outstanding corrosion resistance

Casting

An object made by pouring molten metal or other material into a mold

Check valve

A valve that allows fluid to flow in only one direction

Domestic

A product that is manufactured within the USA

Durometer

An instrument for testing the hardness of various plastics and rubbers

Extrude

A process to shape a material, metal or plastic, by forcing it through a die

Fluorocarbon (*viton*)

A synthetic rubber and fluoropolymer elastomer commonly used in O-rings and other molded or extruded products

Forge

A process involving the shaping of metal using localized compressive force

Galvanize

A type of coating with a protective layer of zinc

Gooseneck

A pipe curved like a goose's neck used on inverted vent check valves typically found on the deck of a vessel

GPM

Gallons per minute

JIC

A type of flare fitting machined with a 37° or 45° flare seating surface

Marine rated

A product's ability to withstand elements associated with marine environments

Non-domestic

A product that is manufactured outside of the USA

Nitrile (*Buna-N*)

A synthetic rubber copolymer of acrylonitrile (ACN) and butadiene commonly used in O-rings and gaskets

NPS

National Pipe Straight Thread

NPT

National Pipe Taper Thread

Passivate

A process of coating with inert material to protect it from contamination

Polyethylene (PE) (*composite*)

A type of plastic that is made of a versatile material

Powder coat

A type of coating that is applied as a free flowing, dry powder

PSI

Pounds per square inch

Sil-braze

A joining process in which two or more metals are joined together by melting and flowing a filler metal into the joint

Socket weld

A welding technique in which a pipe is inserted into a recessed area of a valve, fitting or flange

Zinc plating

A process where zinc is applied by using a current of electricity

Industry Cross Reference

Product	Hydrasearch	John Gjerde	KPM	Pres-Vac	Tate Andale	Wager	Winel	Winteb
Air pipe head (<i>aluminum</i>)	APH-A	HIDE 1	-	-	-	-	CM	WIN2000 HAIS
Air pipe head (<i>steel</i>)	APH-GS APH-SS	Aero 1.1	-	M4	-	1500	RM	-
Inverted vent check valve	PM1	Aero 1.6	1027	SO	52-20	1700	-	WIKO 5000
Inverted vent check valve (with closing device)	PM1...-C	-	1027	SOC	52-25	1750	-	-
Deck drain	DD	-	1016	-	60-100	134	-	-
Deck drain (<i>2:1 ratio</i>)	DD21	-	-	-	60-140	136	-	-
Deck drain (<i>heavy wall</i>)	DDXH	-	1023	-	60-150	246	-	-
Sounding tube	ST	-	1009-M	-	58-60/61	133	-	-

Product	Hydrasearch	Aeroquip	Parker
Hydraulic fittings	CR-48A, AN-48A	411 Series	23 Series
Hydraulic hose	n/a	100R5, 302A, 303, 1503, 1540, 2580, 2651, FC234, FC300, FC321, FC350, FC355, FC558 and FC802	213 and 285

Hydrasearch Naming Convention

- The below part number convention covers standard items
- Any non-standard items (i.e. float options, add-on closing device, etc) will have additional extensions on the part number
- Part numbers beginning alphabetically do not follow the below convention



Size (inches)	Series	Material	Connection
1.5"	APH-A (aluminum air pipe head) ¹	A (aluminum)	F (flanged)
2"	APH (air pipe head)	B (bronze)	S (socket weld)
2.5"	PM1 (inverted vent check valve)	GS (galvanized steel)	T (threaded)
3"	DD (deck drain)	SS (stainless steel)	W (butt weld)
4"	DD21 (2:1 ratio deck drain)		SIL (sil-brazed)
5"	DDXH (heavy wall deck drain)		
6"	ST (sounding tube)		
8"	SMB (suction bellmouth)		
10"	SSB (suction strainer box)		
12"			

Notes

- 1 The APH-A option does not require an additional "A" notation when creating the part number.

Legal Policy Information

Warranty Policy

Right to warn

In order to ensure proper function of products, it is strongly recommended that each part is inspected and serviced monthly. Inspection should include, but is not limited to, visible damage, excessive wear and proper bonding. Failure to properly maintain your product may result in catastrophic failure and/or loss of life.

Warranty

Hydrasearch Company, LLC (herein called "Hydrasearch") warrants the products described herein, and manufactured by Hydrasearch to be free from defects in material and workmanship for a period of one (1) year from the date of shipment by Hydrasearch under normal use and service. Hydrasearch's sole obligation under this warranty is limited to either repairing or replacing, as hereinafter provided, at its option, any product found to Hydrasearch's satisfaction to be defective upon examination by it, provided that such product shall be returned for inspection to Hydrasearch's factory within thirty (30) days after discovery of the defect.

The repair or replacement of defective products will be made without charge for parts or labor. This warranty shall not apply to parts or products not manufactured by Hydrasearch, the warranty of such items being limited to the actual warranty extended to Hydrasearch by its supplier.

This warranty shall not apply to any product which has been subject to abuse, negligence, accident or misapplication or to any product which has been altered or repaired by anyone other than Hydrasearch nor to normal maintenance services and the replacement of service items (such as washers, gaskets and lubricants) made in connection with such services.

To the extent permitted by law, this limited warranty shall extend only to the buyer and any other person reasonably expected to use or consume the goods who is injured in person by any breach of warranty. No action may be brought against Hydrasearch for an alleged breach of warranty unless such action is instituted within one (1) year from the date the cause of action accrues. This limited warranty shall be construed and enforced to the fullest extent allowable by applicable law.

Other than the obligation of Hydrasearch expressly set forth herein, Hydrasearch disclaims all warranties, expressed or implied, including but not limited to any implied warranties of merchantability or fitness for a particular purpose, and any other obligation or liability. The foregoing constitutes Hydrasearch's sole obligation with respect to damages, whether direct, incidental or consequential, resulting from their use or performance of the product.

Proposition 65 Warning

Hydrasearch Company, LLC is in compliance with the California Safe Drinking Water and Toxic Enforcement Act of 1986 and its supporting regulations ("Proposition 65"). Accordingly, Hydrasearch will defend and indemnify our customers if there is a claim made under Proposition 65 for listed chemicals being contained in its products, so long as our customers provide the warning per the instructions below. Hydrasearch provides warnings that comply with the current Proposition 65 regulations and the amended regulations which took effect August 30, 2018.

All Hydrasearch products are shipped in cartons with the following warning:

 **WARNING:** Cancer and Reproductive Harm - www.P65Warnings.ca.gov."

If you sell or distribute Hydrasearch products to California consumers, or to other persons or entities that may sell such items to California consumers, in quantities fewer than a full carton, you must provide this warning to each customer, either by labeling each unit with the above warning or by another method.

If you would like more information about the chemicals contained in Hydrasearch products, please visit our website at www.hydrasearch.com. Many product display pages contain information about the chemicals contained in our products.

Hydrasearch products made of brass may not be sold to California consumers unless such fittings either contain less than 300 PPM of lead when analyzed pursuant to the EPA test method 3050B or equivalent or they are sold or distributed with a clear, reasonable and conspicuous warning. So long as it is prominently displayed on the product or the packaging of the product, the following warning complies for brass fittings:

"WARNING: This product contains a chemical known to the State of California to cause birth defects or other reproductive harm. Do not use in connection with drinking water. Wash hands after handling."

There are significant penalties associated with failure to comply with Proposition 65 requirements. Should you need further explanation or assistance in complying with this notice, please do not hesitate to **contact us at compliance@hydrasearch.com**.

Legal Policy Information

Return Policy

Contact your Hydrasearch Company, LLC customer service representative (information below) to obtain a Return Material Authorization (RMA) form. Original invoice number, purchase order number and date must be provided. Product returned without an RMA number may be refused or returned at the customer's expense. Hydrasearch is not liable for unauthorized returns.

Return Material Authorization (RMA)

- Authorization must be obtained prior to return
- RMA expires thirty (30) days from date issued
- One carton must include a copy of the RMA form to ensure prompt evaluation and possible credit on return
- Returned merchandise transportation must be prepaid
- Merchandise must be packed well to avoid damage during transit
- All cartons must be marked with authorized RMA number (unmarked shipments will be refused by our receiving department)
- Returned goods should be shipped to the following address:

Hydrasearch Company, LLC
Returned Good Dept. RMA # _____
203A Log Canoe Circle
Stevensville, MD 21666

Nonconforming Products

- All product will be inspected and processed by our quality department for disposition
- Products shipped in error and/or product deemed nonconforming will be credited at the invoice price paid including freight charges for these items

Restocking/Unwanted Products

- All product will be inspected and processed by our quality department for disposition
- Restocking charge will apply at a minimum of 25% for all product returned for any other reason than Hydrasearch shipping and/or nonconforming errors
- Product returned damaged/broken will be credited at a scrap value only
- Product returned to Hydrasearch must be prepaid freight at the responsibility of the customer
- Non-inventory product may or may not be authorized for return, based solely on the inventory requirements of Hydrasearch
- Orders that do not have standard requirements, are not eligible for return (*unless product is found to be nonconforming by our quality department*)
- Shaft Couplings must be in original, sealed cartons and in salable condition

Claims

- Claims for damage or loss in transit must be made by customer directly against the carrier. Hydrasearch is not responsible for freight damage
- Photographic evidence is required for all claims
- All claims for defective product or deficient orders must be made in writing by customer within thirty (30) days of receipt

Hydrasearch Sales Representatives

Commercial
Phone: 410.643.8900
Email: commercial@hydrasearch.com

APH-A Series (aluminum)

- Prevents seawater from entering tanks
- Allows air/vapor to escape when tank is filling
- Allows air intake when tank is discharging
- Vertical orientation is ideal for reducing weight and eliminates the need for a gooseneck pipe bend

Specifications

Construction	Cast aluminum housing
Hardware	Stainless steel
Nitrile seal (Buna-N)	Maximize low pressure sealing Oil and fuel resistant
Flange holes	Oblong; to accommodate ANSI B16.5 and DN PN10/16 flange mount dimensions
Float	Full round High density polyethylene (HDPE)
Screen	30 mesh Corrosion resistant for ignition protection Easily accessible for maintenance Design allows for closing option with screen in place
Seal retaining ring	Easy replacement of valve seal
Cap	Top mounted
Closing device	Optional
Compliances	ABS



Dimensions

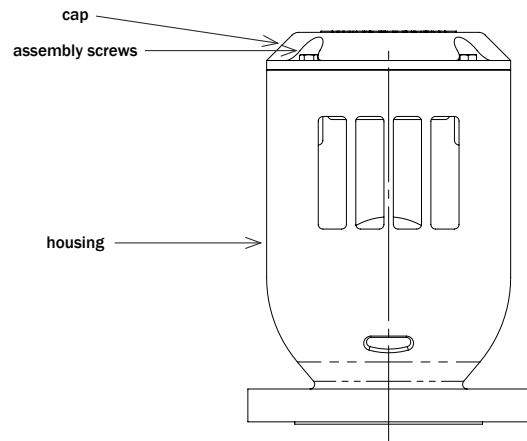
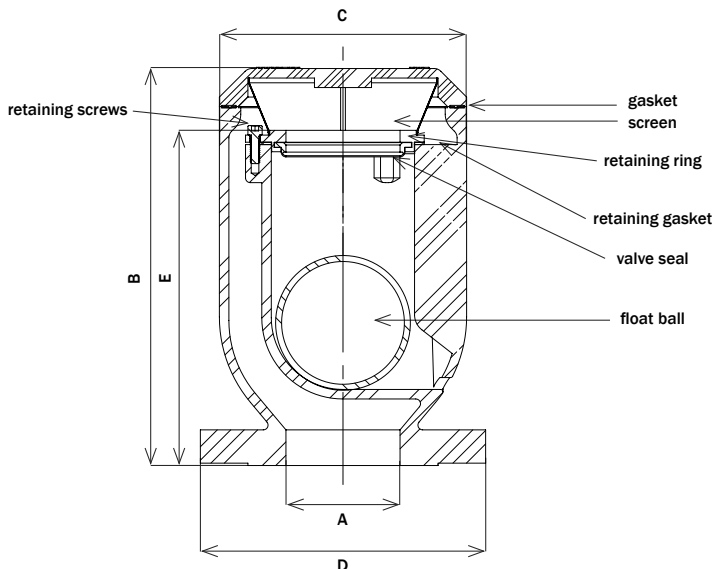

APH-A Series (aluminum)

Product Specifications and Ordering Information

Example: 2-APH-A-F-R

Part No.	A (size)	B	C	D	E	Approximate weight (pounds)	Max inlet air speed (m/s)	Inlet air flow rate at max inlet air speed (m ³ /hr)	Flow rate at 3.625 PSI (GPM)
2-APH-A-F-R	2	8.63	5.5	6	6.75	7	12.4	90	95
2.5-APH-A-F-R	2.5	9.25	6	7	7.63	9	19.6	223	120
3-APH-A-F-R	3	10.5	6.5	7.5	8.75	11	21.8	358	178
4-APH-A-F-R	4	12.38	8	9	10.5	16	18.7	546	288
5-APH-A-F-R	5	14.75	10	10	12.25	25	19.2	875	420
6-APH-A-F-R	6	16.25	11.63	11	13.25	33	12.8	838	680
8-APH-A-F-R	8	21.25	14.63	13.5	17.25	56	-	-	-
10-APH-A-F-R	10	27.25	18.13	16	22.25	104	-	-	-
12-APH-A-F-R	12	31	22.13	19	25.25	151	-	-	-

Note: All dimensions are in inches and are for reference only

Air intake tested with polyethylene float (lightest float) and the water pumped through the air pipe head for the flow rate

Ordering Note: To order the threaded option replace the “F” with a “T” in the part number, example: 2-APH-A-T-R
 To order a closing device add “-C” to the end of the part number, example: 2-APH-A-F-R-C

Pressure Loss vs Flow Rate

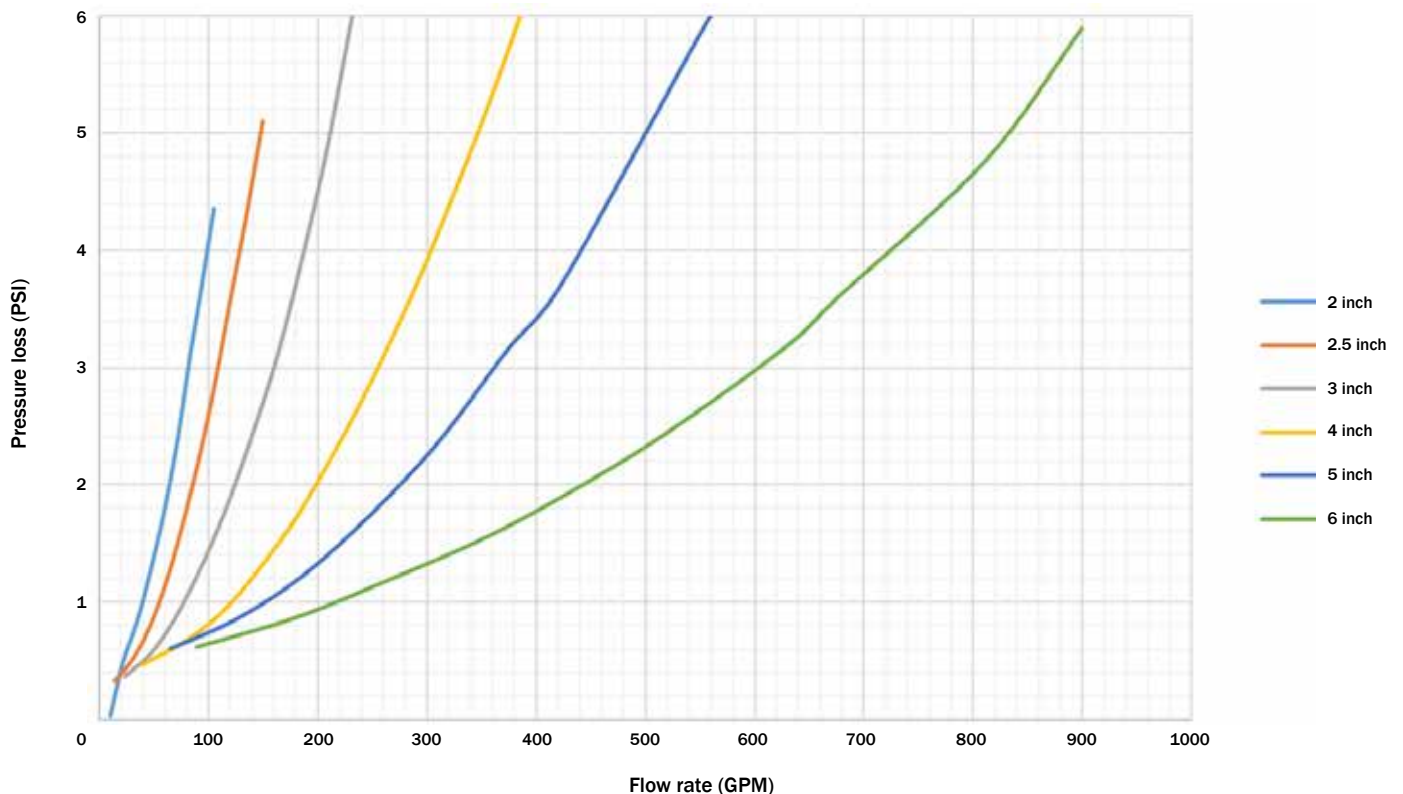

APH Series (steel)

- Prevents seawater from entering tanks
- Allows air/vapor to escape when tank is filling
- Allows air intake when tank is discharging
- Vertical orientation is ideal for reducing weight and eliminates the need for a gooseneck pipe bend



Specifications

Construction	Cast housing, 2 - 4 inch Fabricated, 5 - 12 inch Recessed cap; eliminates catch points (fabricated) Internal housing is removable for easy maintenance
Hardware	Stainless steel
Nitrile seal (Buna-N)	Maximize low pressure sealing Oil and fuel resistant
Flange holes	Oblong; to accommodate ANSI B16.5 and DN PN10/16 flange mount dimensions
Connection	Flanged - standard
Float	Full round Stainless steel - standard High density polyethylene (HDPE) - option
Screen	Corrosion resistant for ignition protection Easily accessible for maintenance
Cover	Downward facing; aids in the containment of overflows
Closing device	Optional upon request
Compliances	ABS

Dimensions

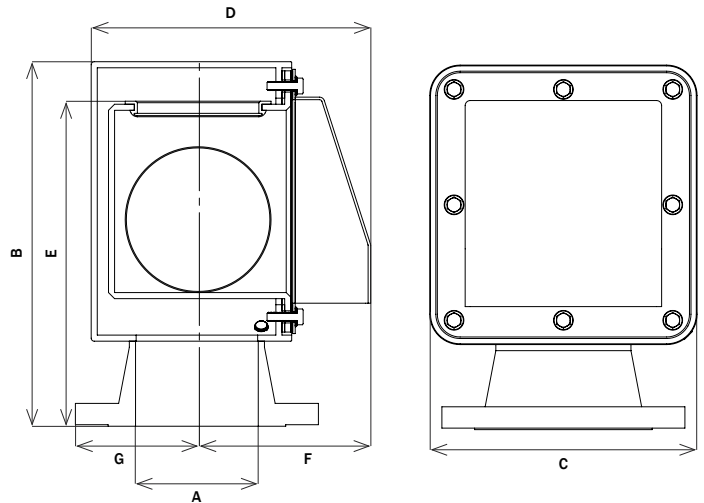

Ordering Information

Example: 2-APH-GS-F-C-P

Size (inches)	Series	Material	Connection	Construction ¹	Float option ²
2	APH (air pipe head)	GS (galvanized steel)	F (flanged)	C (cast housing)	P (polyethylene)
2.5		SS (stainless steel 316)	S (socket weld)		
3			T (threaded)		
4			W (butt weld)		
5					
6					
8					
10					
12					

Notes

- ¹ The cast housing construction is only available in 2 - 4 inch, all other sizes are fabricated and do not require a notation when creating the part number
- ² The standard option (stainless steel) does not require a notation when creating the part number.

APH Series (steel)

Product Specifications

Part No.	A (size)	B	C	D	E	F	G	Approximate weight (pounds)	Max inlet air speed (m/s)	Inlet air flow rate at max inlet air speed (m ³ /hr)	Flow rate at 3.625 PSI (GPM)
2-APH-GS-F-C	2	8.63	6	7.5	7.5	4.5	3	24	36	261	150
2.5-APH-GS-F-C	2.5	8.63	6	7.5	7.5	4.5	3.5	26	22	251	160
3-APH-GS-F-C	3	11.75	8.5	10.5	10.38	6.25	4.25	50	27	441	315
4-APH-GS-F-C	4	11.75	8.5	10.5	10.38	6.25	4.5	53	15	447	325
5-APH-GS-F	5	15	11	11.5	13.38	7.17	5	83	19	1079	540
6-APH-GS-F	6	18	13.5	14.13	15.88	9	5.5	124	24	1973	780
8-APH-GS-F	8	22.5	16.5	17.5	20	10.8	6.75	196	27	3924	1410
10-APH-GS-F	10	24.5	20.5	20.75	21.63	13	8	280	33	7476	1900
12-APH-GS-F	12	29	23.5	24.38	25.63	15.31	9.5	392	26	8582	2700

Note: All dimensions are in inches and are for reference only

Air intake tested with polyethylene float (lightest float) and the water pumped through the air pipe head for the flow rate

Weight is based on the galvanized steel material with a stainless steel float and may vary with different material

Pressure Loss vs Flow Rate

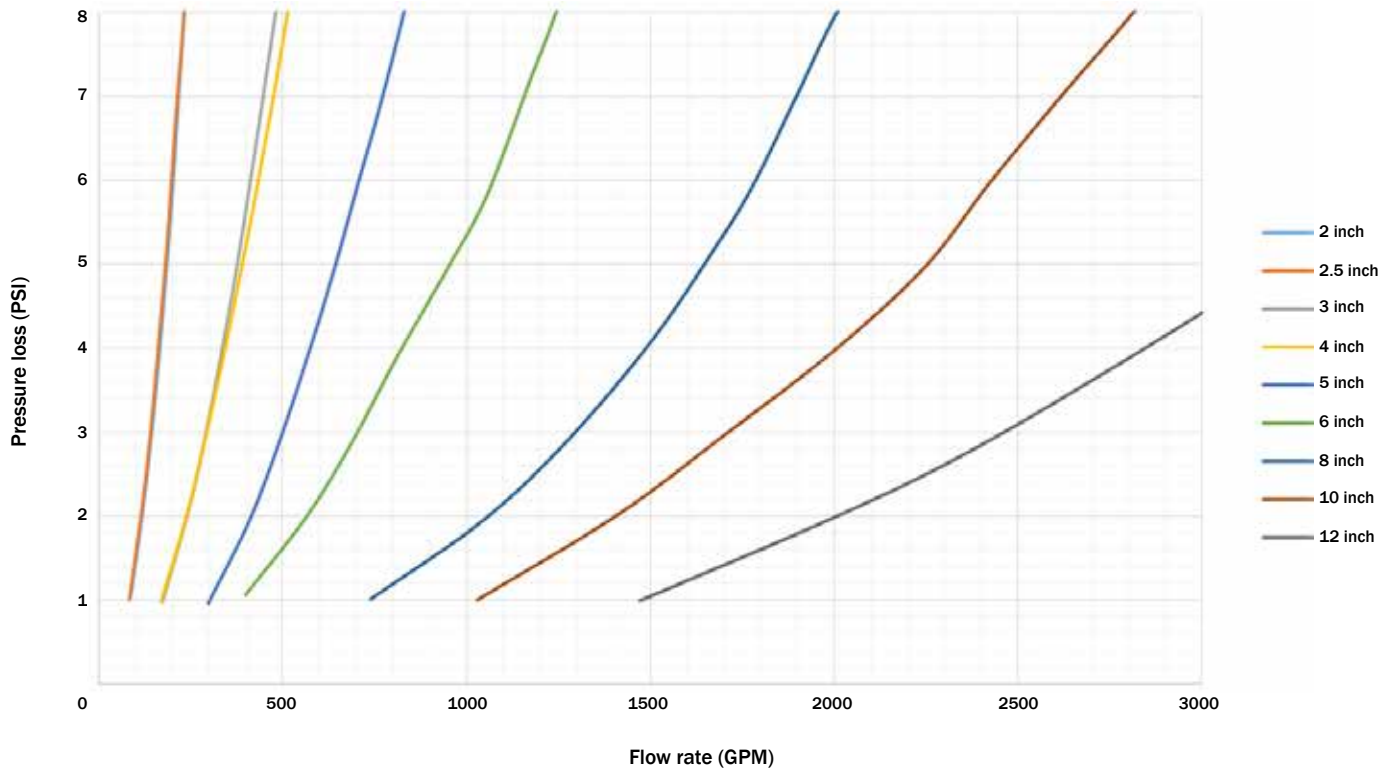

PM1 Series Full Float

- Prevents seawater from entering tanks
- Allows air/vapor to escape when tank is filling
- Allows air intake when tank is discharging
- Inverted (gooseneck) design offers simplest means for your requirements
- Design makes disassembly fast and easy



Specifications

Construction	Four (4) guide ribs to assure proper sealing Recessed cap; eliminates catch points
Hardware	Stainless steel
Nitrile seal (Buna-N)	Maximize low pressure sealing Oil and fuel resistant
Float	Full round Stainless steel - standard High density polyethylene (HDPE) - option
Screen	Corrosion resistant for ignition protection Easily accessible for maintenance
Cap	Eliminates need for a spacer ring and protective screen
Closing device	Optional
Compliances	ABS

Dimensions

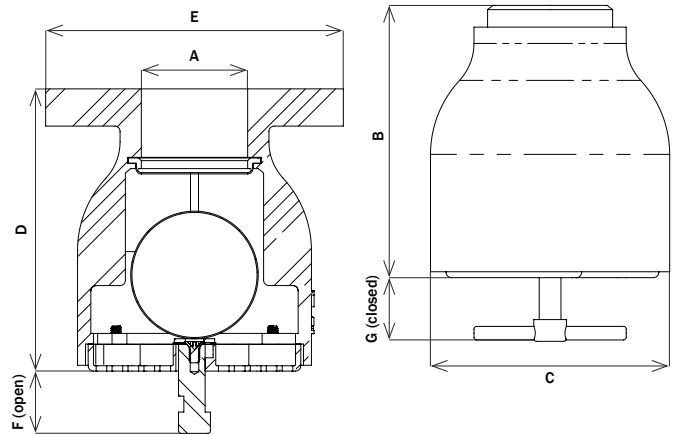

Ordering Information

Example: 1.5-PM1-A-F-P-C

Size (inches)	Series	Material	Connection	Float option ²	Closing options	
1.5	PM1 (inverted valve)	A (aluminum 535)	F (flanged)	P (polyethylene)	C (closing device)	
2		B (bronze B62)	S (socket weld)			
2.5		GS (galvanized steel)	T (threaded)			
3		SS (stainless steel 316)	W (butt weld) ¹			
4						

Notes

- 1 Butt weld not available in bronze (B26) material
- 2 The standard option (stainless steel) does not require a notation when creating the part number.

PM1 Series Full Float

Product Specifications

A (size)	B	C	D	E	F	G	Approximate weight (pounds)	Approximate flanged weight (pounds)	Max inlet air speed (m/s)	Inlet air flow rate at max inlet air speed (m ³ /hr)	Flow rate at 2.0 PSI (GPM)
1.5	4.63	4	4.75	5	1.5	0.5	5	8	27	109	56
2	6.13	5	6.38	6	2	0.5	9	12	42	306	95
2.5	6.25	5.5	6.63	7	1.88	0.5	10.5	17.5	26	291	190
3	7.38	6.5	7.94	7.5	2	0.5	15	22.5	19	315	205
4	8.88	8	9.31	9	2.5	0.5	23	33.5	25	722	335

Note: All dimensions are in inches and are for reference only

Air intake tested with polyethylene float (lightest float) and the water pumped through the vent check valves for the flow rate
 Weight is based on the galvanized steel material with a stainless steel float and may vary with different material

Pressure Loss vs Flow Rate

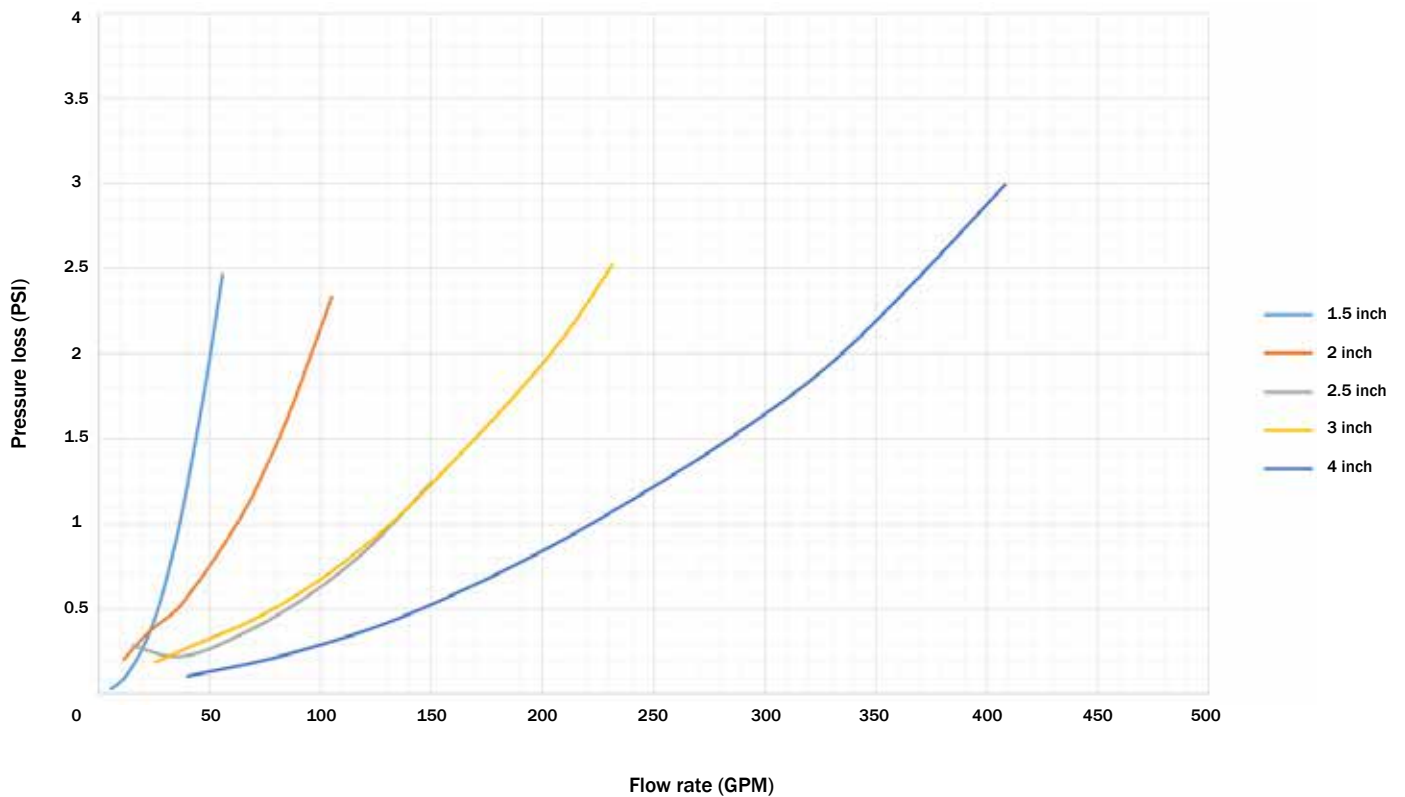

PM1 Series Half Float



- Prevents seawater from entering tanks
- Allows air/vapor to escape when tank is filling
- Allows air intake when tank is discharging
- Inverted (gooseneck) design offers simplest means for your requirements
- Design makes disassembly fast and easy

Specifications

Construction	Four (4) guide ribs to assure proper sealing Recessed cap; eliminates catch points
Hardware	Stainless steel
Nitrile seal (Buna-N)	Maximize low pressure sealing Oil and fuel resistant
Float	Half round; flat side up allows improved sealing Stainless steel - standard High density polyethylene (HDPE) - option
Screen	Corrosion resistant for ignition protection Easily accessible for maintenance
Cap	Eliminates need for a spacer ring and protective screen
Closing device	Optional
Compliances	ABS

Dimensions

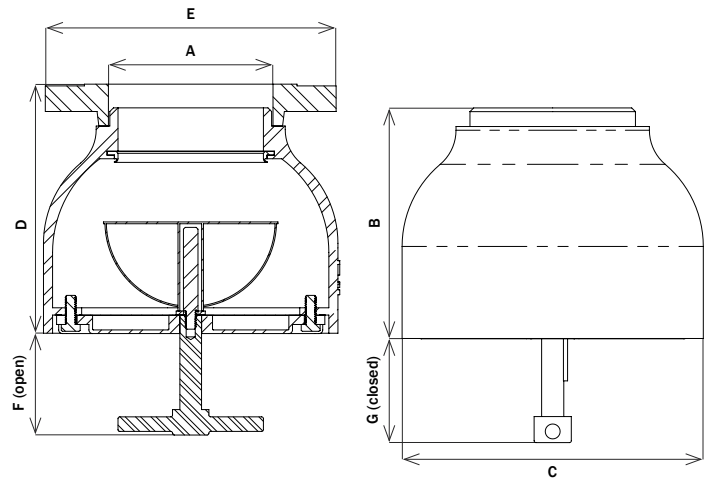

Ordering Information

Example: 5-PM1-A-F-P-C

Size (inches)	Series	Material	Connection	Float option ³	Closing options
5	PM1 (inverted valve)	A (aluminum 535)	F (flanged)	P (polyethylene)	C (closing device)
6		B (bronze B62)	S (socket weld) ¹		
8		GS (galvanized steel)	T (threaded) ¹		
10		SS (stainless steel 316)	W (butt weld) ²		
12					

Notes

- 1 Not available with the 10 and 12 inch
- 2 Not available in bronze (B26) material
- 3 The standard option (stainless steel) does not require a notation when creating the part number.

PM1 Series Half Float

Product Specifications

A (size)	B	C	D	E	F	G	Approximate weight (pounds)	Approximate flanged weight	Max inlet air speed (m/s)	Inlet air flow rate at max inlet air speed (m ³ /hr)	Flow rate at 2.0 PSI (GPM)
5	7.75	10.13	8.25	10	3.5	1	29	43	10	470	690
6	8.5	11.13	9	11	3.5	1	35	52	9	560	890
8	10	14.13	10.75	13.5	3.5	1	54	82	8	945	1520
10	12.5	17	13.25	16	4.25	1	90	127	9	1710	2000
12	14.5	21	15.75	19	5	1	138	195	9	2495	3500

Note: All dimensions are in inches and are for reference only

Air intake tested with polyethylene float (lightest float) and the water pumped through the vent check valves for the flow rate
 Weight is based on the galvanized steel material with a stainless steel float and may vary with different material

Pressure Loss vs Flow Rate

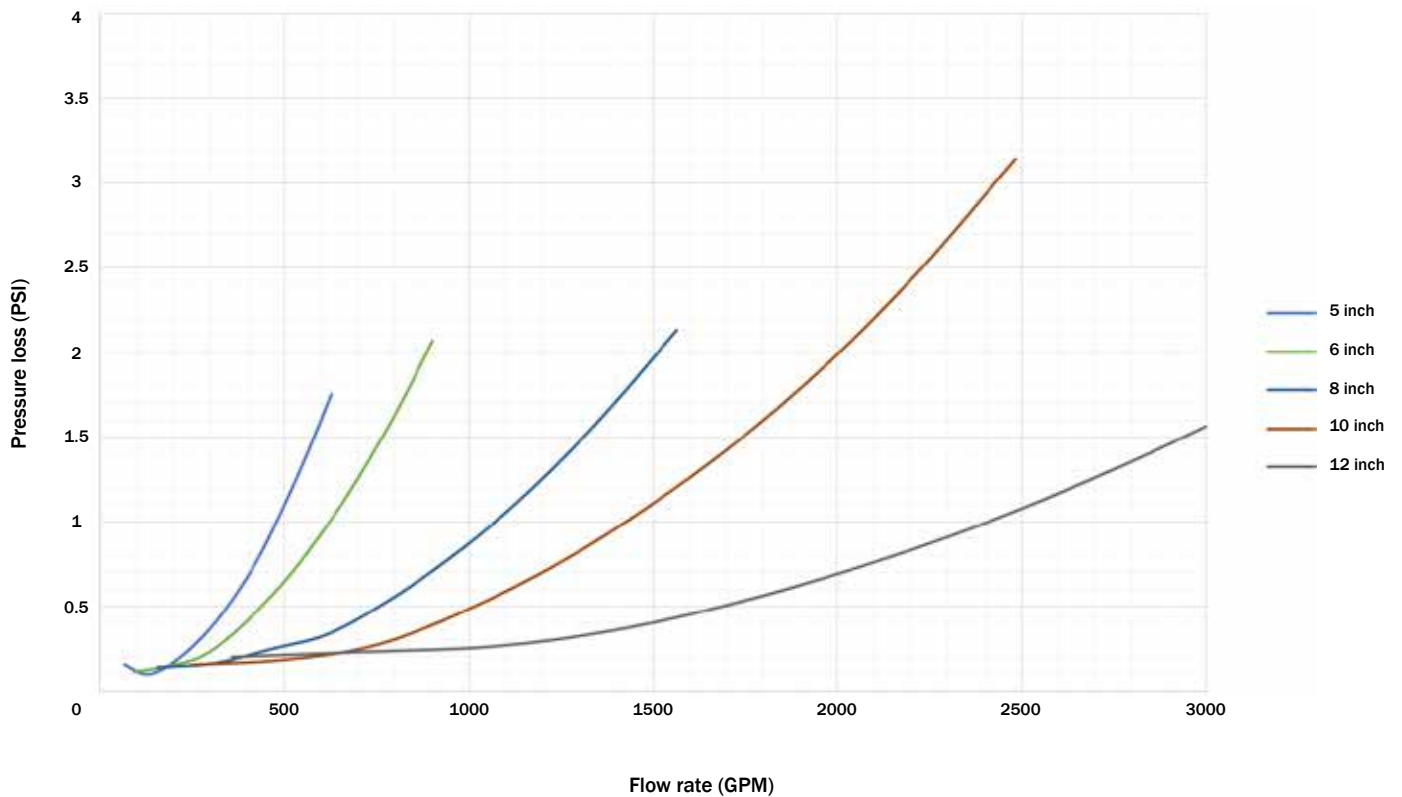

Deck Drains

- Ensures water can escape from deck with ease
- Available in multiple designs
- Easy installation



Heavy Wall

Standard and 2:1 Ratio

Specifications

Construction	Cast housing
Hardware	Stainless steel
Strainer	Bronze (B62) - standard
Designs	Standard
	2:1 Ratio
	Heavy wall, comes with trap and baffle

Product Specifications

A (size)	B	C	D	Open area ratio	Approximate max weight (pounds)
Standard Deck Drain					
1.5	3.25	4.5	3.88	2.5:1	4
2	3.25	4.5	3.88	1.4:1	4
2.5	3.75	5.5	4.88	1.6:1	6.5
3	3.75	5.5	4.88	1.1:1	6
4	3.75	6.5	5.88	1.1:1	8
6	5	11.75	10.88	1.3:1	25
Heavy Wall Deck Drain					
1.5	3.88	4.13	4.25	3:1	7
2	4	5.13	5.25	3:1	10.5
2.5	4.25	6.25	6.38	2.5:1	10
2:1 Ratio Deck Drain					
2	4	5.75	5.25	2.5:1	10.5
3	3.75	6.5	6	2:1	9

Note: All dimensions are in inches and are for reference only

Weight is based on the galvanized steel material and may vary with different material

Dimensions

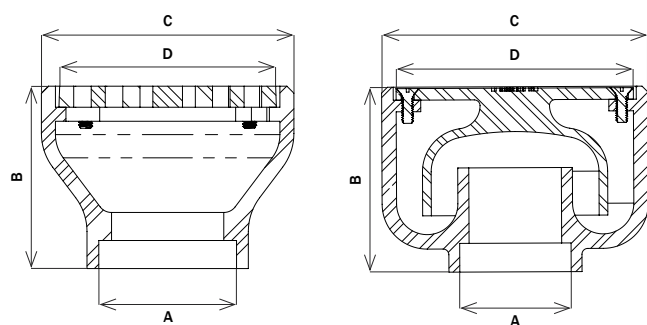

Standard and 2:1 Ratio

Heavy Wall

Ordering Information

Example: 1.5-DD-A-S-A

Size (inches)	Series	Material	Connection	Strainer options
1.5	DD (standard)	A (aluminum 535) ³	S (socket weld)	A (aluminum 535) ³
2	DDXH (heavy wall) ¹	GS (galvanized steel)	T (threaded)	B (bronze B62)
2.5	DD21 (2:1 ratio) ²	SS (stainless steel 316)	W (butt weld)	SS (stainless steel 316)
3				
4				
6				

Notes

- 1 Only available in 1.5, 2 and 2.5 inch
- 2 Only available in 2 and 3 inch
- 3 Only available on the Standard series (DD) in the 1.5 and 2 inch size

Suction Bellmouths



- Designed for use in ship bilges to help with final stripping of liquid cargo tanks
- Prevents vortex and gas formation
- Minimizes hydraulic loss while pumping liquids
- Flush without shutting down

Specifications

Construction	Fully cast carbon steel (1025)
Open area ratio	1.5:1 open area ratio to pipe size
Connections	Butt weld (beveled end) and flanged

Dimensions

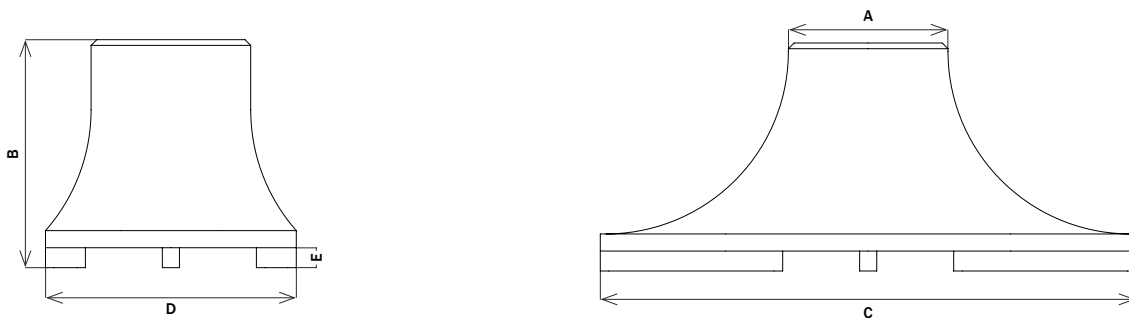

Product Specifications and Ordering Information

Example: 3-SBM-O-W

Part No.	A (size)	B	C	D	E	Approximate weight (pounds)
3-SBM-O-W	3.5	5	11.75	5.5	0.44	7
4-SBM-O-W	4.5	6.75	15.25	6.75	0.5	13
5-SBM-O-W	5.56	8.38	19.25	8.25	0.63	21
6-SBM-O-W	6.63	10	23.25	10	0.75	34
8-SBM-O-W	8.63	13.38	30.75	13.75	1	67
10-SBM-O-W	10.75	16.75	39	16.75	1.25	122
12-SBM-O-W	12.75	20	45.38	21.38	1.5	174

Note: All dimensions are in inches and are for reference only

Sounding Tubes

- Provides a watertight closing device, which is accessible under normal operating conditions to enable sounding of the tanks

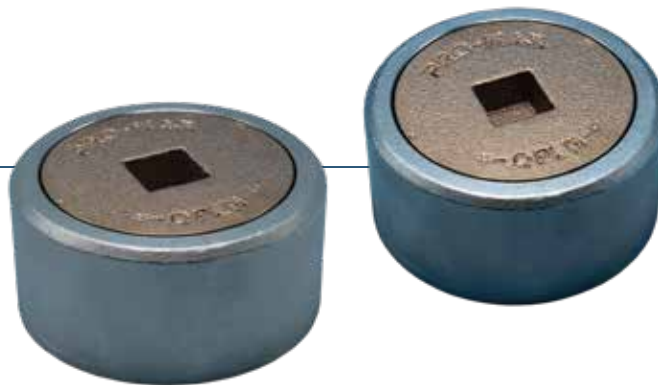

Specifications

Hardware	Stainless steel
Connection	Socket weld
Threaded plug	Bronze (B62) - standard Venting grooves allow venting without fully removing the plug Tether chain
Nitrile gasket	Oil and fuel resistant
T-wrench	Galvanized steel, part number ST-W (sold separately)
Square size	0.75 inch x 0.75 inch

Dimensions

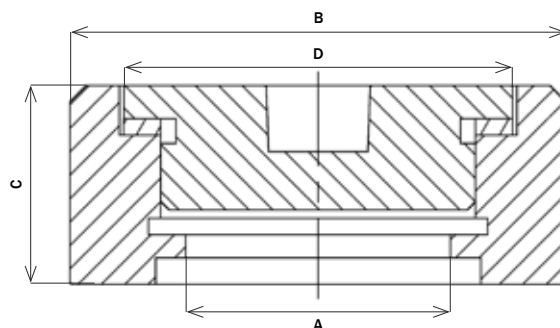

Product Specifications

A (size)	B	C	D	Plug thread (NPSM)	Approximate weight (pounds)
1.5	3.75	1.75	2.95	2 - 11.5	4.5
2	3.75	1.75	2.95	2 - 11.5	4.5
2.5	4.75	1.75	4.06	3-8	6.5
3	4.75	1.75	3.8	3-8	6.5

Note: All dimensions are in inches and are for reference only
Weight is based on the stainless steel material and may vary with different material

Ordering Information

Example: 1.5-ST-A-SS

Size (inches)	Item	Body material	Threaded plug option ¹
1.5	ST (sounding tube)	A (aluminum 535)	SS (stainless steel 316)
2		GS (galvanized steel)	
2.5		SS (stainless steel 316)	
3			

Notes

- The standard option (Bronze B62) does not require a notation when creating the part number.

Pipe Caps



- Not intended for pressure applications
- For debris and thread protection only

Specifications

Construction	Pin lug Chain included
---------------------	---------------------------

Product Specification and Ordering Information

Example: FC150

Part No.	Size (inches)	Body material	Thread	Weight (pounds)
FC150	1.5	cast brass	NPSH	0.40
FC200	2	cast brass	NPSH	0.88
FC250	2.5	cast brass	NPSH	1.19
FC300	3	cast brass	NPSH	2.65
FC400	4	cast brass	NPSH	3.55
FC600	6	cast brass	NPSH	10.94

Note: All dimensions are in inches and are for reference only
 Thread is compatible with NPSM
 Other sizes, threads and finishes are available. Contact factory.

Suction Strainer Box (Rosebox Strainer)



- Designed for use in ship bilges and tank locations, which require trash protection for suction pipes and pumps

Specifications

Hardware	Stainless steel
Connection	OD compression collar

Ordering Information

Example: 2-SSB-A

Size (inches)	Item	Material
2	SSB (suction strainer box)	A (aluminum 535)
2.5		GS (galvanized steel)
3		SS (stainless steel 316)
4		
5		
6		
8		
10		
12		

Dimensions

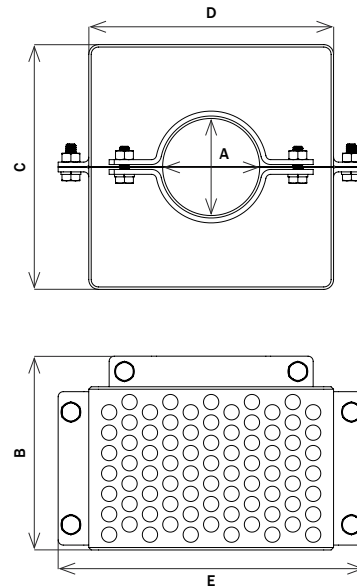

Product Specifications

A (size)	B	C	D	E	Approximate weight (pounds)	OA ratio
2	4.75	6	6	7.5	5	10:1
2.5	4.75	6	6	7.5	5	7:1
3	4.75	6	6	7.5	5	5:1
4	9.5	10	10	12	15	10:1
5	9.5	10	10	12	15	7.5:1
6	9.5	10	10	12	15	4.5:1
8	11	18	18	20	37	5.7:1
10	11	18	18	20	37	3.6:1
12	11	18	18	20	35	2.5:1

Note: All dimensions are in inches and are for reference only
 Weight is based on the galvanized steel material and may vary with different material



Round Hole Strainer

- Designed for use on the submersed end of a suction hose to prevent debris from entering pump
- Not for compressed air or gases

Dimensions

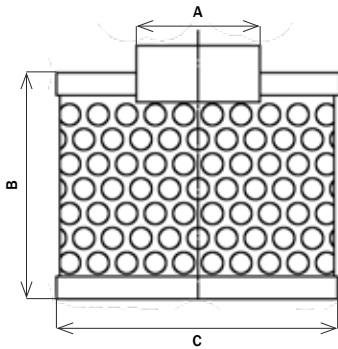

Specifications

Construction	Zinc plated steel
Connection	Thread (NPSM)

Product Specification and Ordering Information

Example: RHS20

Part No.	A (size)	B	C (diameter)	Thread	Weight (pounds)	OA ratio
RHS20	1.5	4	4.88	NPSM	1.5	6.8:1
RHS25	2	4	4.88	NPSM	2	3.8:1
RHS30	2.5	3.5	6	NPSM	2.25	5.9:1
RHS35	3	5	7	NPSM	3	5.4:1
RHS40	4	5	7	NPSM	3.25	3:1
RHS60	6	9.5	9	NPSM	6.25	5.1:1
RHS80	8	11.5	11	NPSM	19.5	4.5:1
RHS100	10	18	15	NPSM	40	5.5:1
RHS120	12	24.5	17	NPSM	31	5.8:1

Note: All dimensions are in inches and are for reference only

Arctic Steel Strainers

- Cast stainless steel water strainers
- Cast with duplex stainless steel (2205) for an exceptional level of corrosion resistance
- Designed to create a swirl action to quickly scavenge air while maximizing full height of the basket

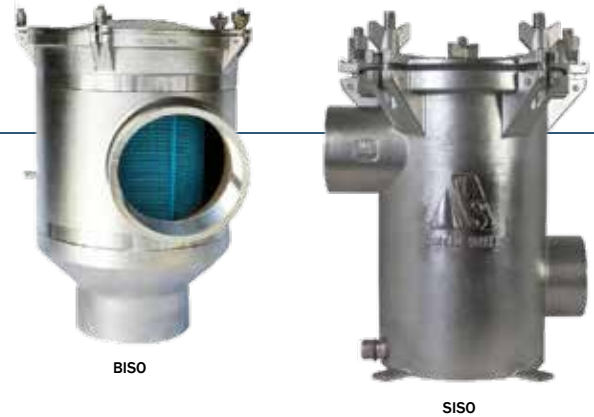

Specifications

Construction	Duplex stainless steel (2205) Electro polishing - AISI cast stainless steel (2205)
Hardware	Stainless steel Five (5) wing nuts - no tools required
Basket	ABS, plastic standard on 1", 1.25" and 1.5" Stainless steel (316) standard on 2", 2.5", 3" and 4"
Thread	SISO - offset inlet and outlet, FNPT threaded BISO - MNPT thread inlet and FNPT thread outlet for 1 - 2 inch options BISO - FNPT thread inlet and FNPT thread outlet for 2.5 - 6 inch options BISO - BSP or NPT threads available
Lid	Solid electro polished stainless steel - standard Clear interchangeable polycarbonate lid - option Easy access for maintenance

Dimensions

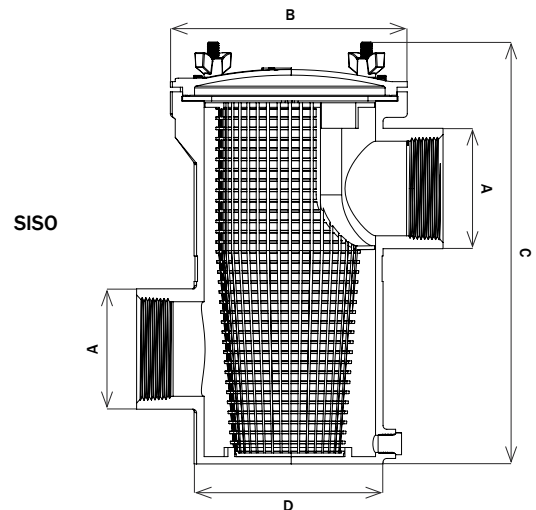

Ordering Information

Example: 70WS-BISO-100-C

Item	Orientation	Pipe size ¹	Lid Option
70WS (strainer)	BISO (bottom in side out)	100 (1 inch)	C (clear)
	SISO (side in side out)	125 (1.25 inch)	S (solid)
		150 (1.5 inch)	
		200 (2 inch)	
		250 (2.5 inch)	
		300 (3 inch)	
		400 (4 inch)	
		600 (6 inch) ²	

Notes

- 1 See basket specification for basket material standards determined by size
- 2 Only available with the BISO orientation

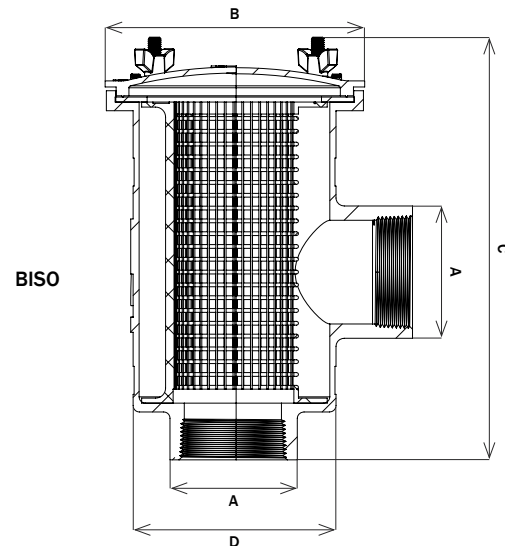

Arctic Steel Strainers

Product Specifications

Thread size (inlet/outlet) (A)	Lid width (B)	Height (C)	Body width (D)	Approximate weight with solid lid (pounds)	Flow rate 1.45 PSI (GPM)	Flow rate 14.5 PSI (GPM)
SISO Strainers						
1 - 11.5 female/female	6	9.3	5.2	8	25	85
1.25 - 11.5 female/female	7.9	10.6	5.2	15	40	126
1.5 - 11.5 female/female	7.9	10.6	5.2	15.4	56	180
2 - 11.5 female/female	7.9	10.6	5.2	16	89	282
2.5 - 8 female/female	9.25	14.4	6.5	30	148	483
3 - 8 female/female	9.25	14.4	6.5	32.6	228	743
4 - 8 female/female	10.7	18.8	8.7	45.2	451	1450
BISO Strainers						
1 - 11.5 male/female	5.6	8.3	3.7	6.8	37	114
1.5 - 11.5 male/female	5.6	8.3	3.7	7.1	86	272
2 - 11.5 male/female	6.7	10.7	5.5	14.8	128	427
2.5 - 8 female/female	7.9	10.7	5.5	13.7	169	569
3 - 8 female/female	9.25	13.1	6.5	27.6	257	792
4 - 8 female/female	10.7	18.7	8.7	40.8	487	1545
6 - 8 female/female	14.2	20.1	12.2	66.8	841	2718

Note: All dimensions are in inches and are for reference only

Pressure Loss vs Flow Rate

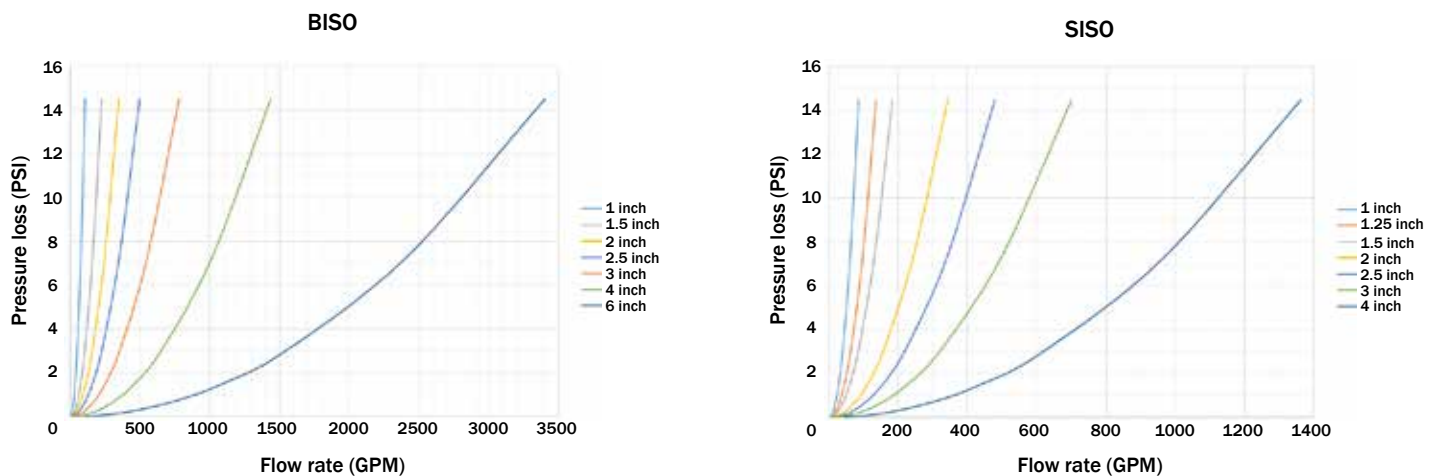

Note: All flow rates calculated using a clean ABS basket

Cast Iron Threaded Foot Valves

- For use on water suction hoses
- Prevents pump from losing its prime



Specifications

Construction	Painted cast iron
Hardware	Stainless steel
Replacement parts	Seat plates Strainer Valve

Product Specification and Ordering Information

Example: DFVS20

Part No.	Material	Size (inches)	Thread	Weight (pounds)
DFVS20	painted cast iron	1.5	NPT	3.1
DFVS25	painted cast iron	2	NPT	5.41
DFVS30	painted cast iron	2.5	NPT	6.98
DFVS35	painted cast iron	3	NPT	9.49
DFVS40	painted cast iron	4	NPT	15.52
DFVS60	painted cast iron	6	NPT	37.8
DFVS80	painted cast iron	8	NPT	85.1

Note: All dimensions are in inches and are for reference only



valve



valve seat plate



strainer



strainer seat plate

Warning

For water service only
Must be installed in the vertical position

Spring Loaded Check Valves



- Soft seat for bubble tight shutoff
- Spring loaded for fast seating action
- Flow profile designed to minimize head loss

Specifications

Construction	Brass
Strainer	Stainless steel
Cracking pressure	0.5 PSI
Seat	NPR
Pressure rating	0.5 inch - 2 inch; 400 PSI WOG 3 inch - 4 inch; 175 PSI WOG
Temperature range	10°F - 210°F (-10°C - 100°C)

Product Specification and Ordering Information

Example: BVFS20

Part No.	Material	Size (inches)	Thread	Weight (pounds)
With strainer				
BVFS20	brass	1.5	female NPT	1.97
BVFS25	brass	2	female NPT	2.4
BVFS35	brass	3	female NPT	7.81
BVFS40	brass	4	female NPT	12.395
Without strainer				
CV050	brass	0.5	female NPT	0.3375
CV075	brass	0.75	female NPT	0.52
CV100	brass	1	female NPT	0.75
CV125	brass	1.25	female NPT	1.18
CV150	brass	1.5	female NPT	1.63
CV200	brass	2	female NPT	2.34
CV300	brass	3	female NPT	6.73
CV400	brass	4	female NPT	12.08

Note: All dimensions are in inches and are for reference only

Gate Valves

- For use with non-shock cold water, oil or gas
- Adjustable packing nut
- Non-rising stem

Product Specification and Ordering Information

Example: BGV25

Part No.	Thread (female)
BGV25	1/4 NPT
BGV38	3/8 NPT
BGV50	1/2 NPT
BGV75	3/4 NPT
BGV100	1 NPT
BGV125	1 1/4 NPT
BGV150	1 1/2 NPT
BGV200	2 NPT
BGV250	2 1/2 NPT
BGV300	3 NPT
BGV400	4 NPT

Note: All dimensions are in inches and are for reference only



Specifications

Construction	Brass
	Iron handwheel
	Threaded bonnet
	Integral seat Solid wedge disc
Pressure rating	200 PSI WOG, cold non-stock

Domestic Full Port Ball Valves

- Full port
- Adjustable packing
- Blow-out proof stem
- Vacuum service to 29 inches Hg

Product Specification and Ordering Information

Example: BBV75FP

Part No.	Port	Thread (female)
BBV75FP	full	3/4 NPT
BBV100FP	full	1 NPT
BBV125FP	full	1 1/4 NPT
BBV150FP	full	1 1/2 NPT
BBV200FP	full	2 NPT

Note: All dimensions are in inches and are for reference only

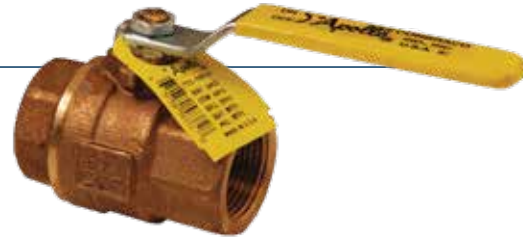

Specifications

Construction	Machined solid chrome-plated ball
	RPTFE seats and stem packing
	Bronze casting
Pressure rating	600 PSI WOG
Saturated steam pressure	150 PSI



Wye Valve - 1/4 Turn Ball

- For use with water only
- Operates easily under high pressure

Product Specification and Ordering Information

Example: S7337S

Part No.	Material	Inlet (female)	Outlet (male)	Weight (pounds)
S7337S	cast brass	2.5 NST (NH)	1.5 NPSH	12.06

Note: All dimensions are in inches and are for reference only
Handles are not field replaceable

Specifications

Construction	Cast brass Rocker lug swivel
Operating pressure	175 PSI at 70°F (21°C)
Certifications	Meets NSN specifications #4210-00-255-0234

Global Angle Valves



- UL Listed
- Factory mutual approved
- Available with a polished or chrome finish

Dimensions

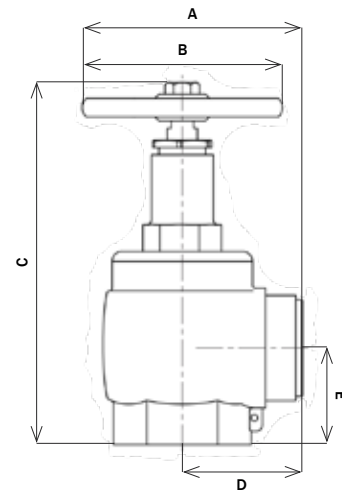

Specifications

Construction	Body - cast, yellow DZR brass alloy Hand wheel - aluminum
Working pressure	300 PSI at 70°F (21°C)

Product Specification and Ordering Information

Example: AV150-I

Cast Part No.	Polished Part No.	Chrome Part No.	Size (inch)	Thread	A	B	C (closed)	C (open)	D	E	Weight (pounds)
AV150-I	AV150-I-P	AV150-I-C	1.5	female NPT inlet, male NH outlet	4.13	3.75	6.8	7.78	2.25	1.81	4.4
AV250-I	AV250-I-P	AV250-I-C	2.5	female NPT inlet, male NH outlet	5.69	5	9	10.72	3.19	2.59	9.5
AVF150-I	AVF150-I-P	AVF150-I-C	1.5	double female, NPT inlet and outlet only	4.13	3.75	6.8	7.78	2.25	1.81	4.4
AVF250-I	AVF250-I-P	AVF250-I-C	2.5	double female, NPT inlet and outlet only	5.69	5	9	10.72	3.19	2.59	9.5

Note: All dimensions are in inches and are for reference only

Industrial Wash Down Nozzles

- Delivers 30° - 60° - 90° fog pattern
- Shutoff - straight stream - fog
- Supplied with bumper
- For water use only

Specifications

Construction	Brass
Pressure rating	100 PSI at 70° F (21° C)



Product Specification and Ordering Information

Example: WDN150

Part No.	Size (inches)	90° spray (GPM at 100 PSI)	Thread	Weight (pounds)
WDN150	1.5	88 (+/- 12)	NPSH	1.4
WDN150NST	1.5	88 (+/- 12)	NST (NH)	1.4

Note: All dimensions are in inches and are for reference only

Fog Nozzles

- Shutoff - straight stream - fog
- Bumper option

Specifications

Construction	Polycarbonate
Hardware	Brass stem
Pressure rating	100 PSI at 70° F (21° C)



Product Specification and Ordering Information

Example: FNB75GHT

Part No.	Part No. (without bumper)	Size (inches)	Thread	90° spray at 100 PSI (GPM)	120° spray at 100 PSI (GPM)
FNB75GHT	-	0.75	GHT	30.9	8
FNB75S	-	0.75	NPSH	30.9	8
FNB100S	FN100S	1	NPSH	30.9	11.4
HGB100S	-	1	NPSH	30.9	-
FNB150S	FN150S	1.5	NPSH	83.6	-
FNB100NST	FN100NST	1	NST (NH)	30.9	11.4
HGB100NST	-	1	NST (NH)	30.9	-
FNB150NST	FN150NST	1.5	NST (NH)	83.6	-

Note: All dimensions are in inches and are for reference only

US Coast Guard Approved AFFF/Water Fog Nozzles



- Designed for maximum efficiency with AFFF (Aqueous Film Forming Foams)
- Ideal for use in shipyards, offshore rigs and industrial applications

Specifications

Construction	Brass
Pressure rating	100 PSI at 70°F (21°C)
Handle	Zytel (nylon) horseshoe
Stream	Double row of molded prongs Flushes without shut down
Gaskets	Gaskets are special order, contact factory

Product Specification and Ordering Information

Example: CGSN150

Part No.	Description	Thread	Fog flow (GPM at 100 PSI)	Approval No.
CGSN150F	nozzle	1.5 NST (NH)	95	162.027/13/0
CGSN151F	nozzle with pistol grip	1.5 NST (NH)	95	162.027/14/0
CGSN150S	nozzle	1.5 NPSH	95	-
CGSN151S	nozzle with pistol grip	1.5 NPSH	95	-

US Coast Guard Approved Fog Nozzles

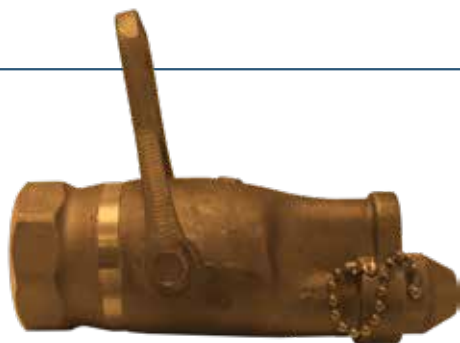

- Designed to U.S. Coast Guard specifications for fighting fires with draft water
- Required equipment for all commercial vessels under US registry

Specifications

Construction	Brass
Pressure rating	100 PSI at 70°F (21°C)
Thread	NST

Product Specification and Ordering Information

Example: CGN150NST

Part No.	Size (inches)	Thread	Fog flow at 100 PSI (GPM)
CGN150NST	1.5	NST	55
CGN250NST	2.5	NST	108

Note: All dimensions are in inches and are for reference only

International Shore Connections

- Makes possible the connection of two different threads between ship and shore or between ships
- Meets US Coast Guard specifications for vessels 1000 gross tons or more

Specifications

Construction	7 inch OD brass flange with 4 ³ / ₄ inch holes Solid wedge disc with tapered seats
Hardware	Eight (8) washers Four (4) hexagon brass nuts Four (4) hex head bolts One (1) washer and one (1) fiber gasket
Thread	NST (NH) - standard NPT and NYFD thread - option
Working pressure	300 PSI - shore side 300 PSI - ship side



Product Specification and Ordering Information

Example: 09-318-00001

Part No.	Material	Thread	Description
09-318-00001	brass	NST (NH)	shore side
09-319-00001	brass	NST (NH)	ship side

100R5 Hydraulic Fittings

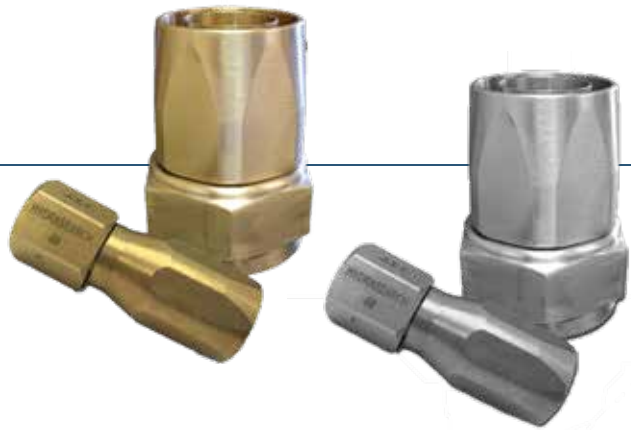

- Field attachable fittings for 100R5 hydraulic hoses
- These 37° flared JIC fittings can be used for a 45° connection
- Ideal for use in repairs at sea and require minimal tooling

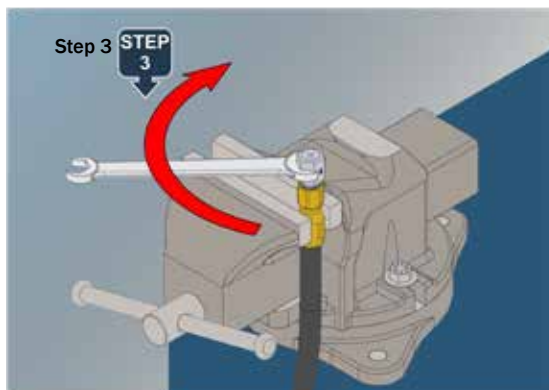
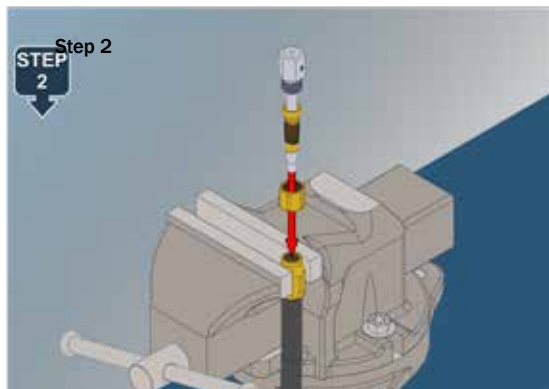
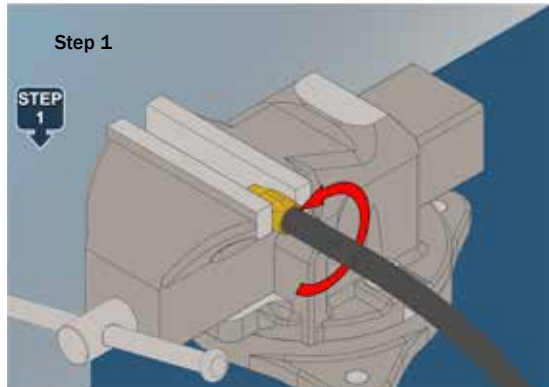

Specifications

Construction	3-piece Brass or stainless steel Includes nut, nipple and socket
Certifications	Produced in accordance with SAE J514

Product Specification and Ordering Information

Example: AN-48A-04

Part No.	Size (inches)	Material
AN-48A-04	1/4	brass
AN-48A-05	5/16	brass
AN-48A-06	3/8	brass
AN-48A-08	1/2	brass
AN-48A-10	5/8	brass
AN-48A-12	3/4	brass
AN-48A-16	1	brass
AN-48A-20	1 1/4	brass
AN-48A-24	1 1/2	brass
CR-48A-04	1/4	stainless steel
CR-48A-05	5/16	stainless steel
CR-48A-06	3/8	stainless steel
CR-48A-08	1/2	stainless steel
CR-48A-10	5/8	stainless steel
CR-48A-12	3/4	stainless steel
CR-48A-16	1	stainless steel
CR-48A-20	1 1/4	stainless steel
CR-48A-24	1 1/2	stainless steel

Note: All dimensions are in inches and are for reference only
Part numbers ending in "-6" and "-12" cannot be used for a 45° connection

AQ-22 Marine Rudders

- Designed for boat speeds up to 40 knots
- Hydrodynamic shape provides proven performance throughout the designed speed range
- Construction, AQ-22 stainless steel

Dimensions

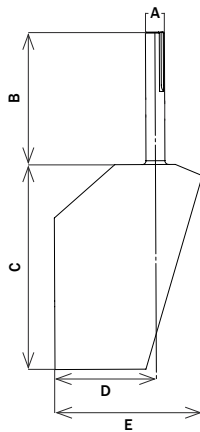

Product Specifications and Ordering Information

Example: 70RMODEL I

Part No.	A	B	Approximate weight stock per foot-pound/foot	Approximate rudder weight less stock pound	C	D	E	Estimated rudder torque 40 knots (inches/pounds)
70RMODEL I	1.25	15	4.17	19	13.5	6.69	9.81	4400
70RMODEL II	1.5	18	6.01	30	16.5	8.25	12	8100
70RMODEL III	1.75	21	8.18	47	19	9.38	13.38	12200
70RMODEL IV	2.25	24	13.52	82	23.38	11.63	17	22300
70RMODEL V	2.75	30	20.19	125	27	13.38	19.5	34300
70RMODEL VI	4	34	42.71	200	31	15.38	22.38	52200
70RMODEL VII	4.5	38	54.05	275	34.5	17	25	71900

Note: All dimensions are in inches and are for reference only
 Custom rudders are available upon request.
 Rudder torque has been increase 25% to allow for bearing friction.

AQ-22 special features

- Wedge sections, creates positive steering forces for a full range of rudder angles
- Designed to trail or track in the slip stream
- Rudder is cut away to minimize ventilation of the rudder during high speed turns
- Cast in stainless steel to provide the strength and positive steering control

AQ-22 Marine Rudders

Rudder Selection

- Estimate of the maximum operating speed and displacement of the boat must be determined
- The speed at which a boat is typically driven will impact the choice of the rudder size
- A single rudder is required for each propeller
- If a specific length is required, it must be stated when ordering the rudder

Boat Characteristics

Boat Characteristic Reference	AQ-22 Rudders
Assumed speed of 25 knots, 28,000 pounds displacement	
One (1) rudder	70RMODELV
Two (2) rudders	70RMODELIII
Three (3) rudders	70RMODELII
Assumed speed of 33 knots and a 38 foot boat	
One (1) rudder	70RMODELIV
Two (2) rudders	70RMODELII
Three (3) rudders	70RMODEL I

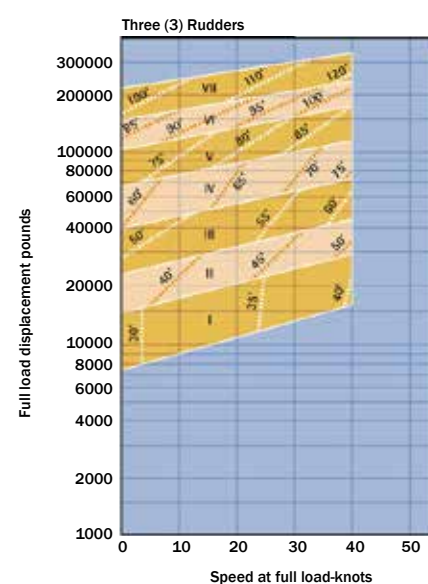
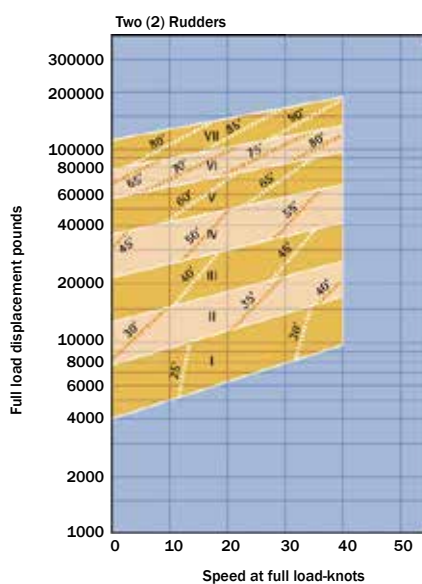
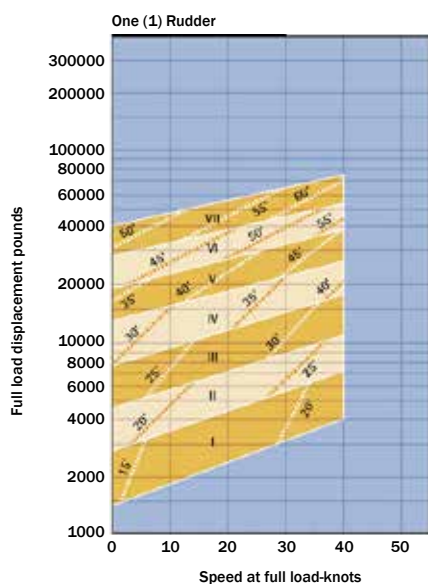
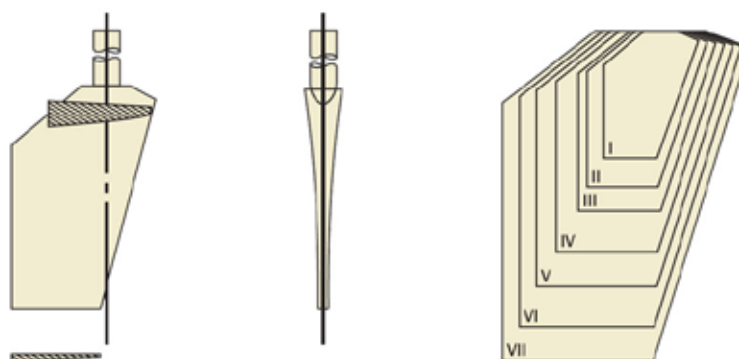

Notes: Numerical value of stock length has been chosen arbitrarily
 Rudder weights are estimated
 Rudder torque is included so that the force required at the tiller arm may be estimated
 Dash lines indicate approximate boat length

Steel Flange Dimensions (ASME B16.5) (150 pound flange)

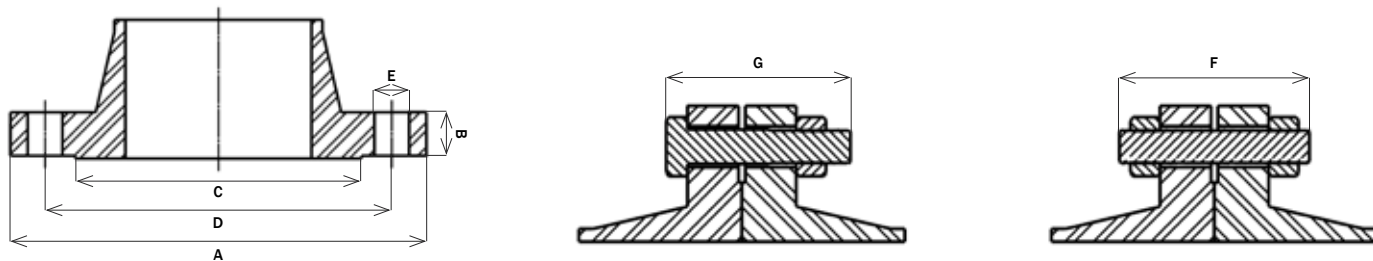

Normal pipe size	Flange diameter (A)	Flange thickness (B)	Diameter of raise face (C)	Diameter of bolt circle (D)	Diameter of bolt hole (E)	Number of bolts	Diameter of bolts	Length of stud bolts with two nuts (F)	Length of machine bolts (G)
1 1/2	5	11/16	2 7/8	3 7/8	5/8	4	1/2	2 3/4	2 1/4
2	6	3/4	3 5/8	4 3/4	3/4	4	5/8	3	2 3/4
2 1/2	7	7/8	4 1/8	5 1/2	3/4	4	5/8	3 1/4	3
3	7 1/2	15/16	5	6	3/4	4	5/8	3 1/2	3
4	9	15/16	6 3/16	7 1/2	3/4	8	5/8	3 1/2	3
5	10	15/16	7 5/16	8 1/2	7/8	8	3/4	3 3/4	3 1/4
6	11	1	8 1/2	9 1/2	7/8	8	3/4	3 3/4	3 1/4
8	13 1/2	1 1/8	10 5/8	11 3/4	7/8	8	3/4	4	3 1/2
10	16	1 3/16	12 3/4	14 1/4	1	12	7/8	4 1/2	3 3/4
12	19	1 1/4	15	17	1	12	7/8	4 1/2	4
14	21	1 3/8	16 1/4	18 3/4	1 1/8	12	1	5	4 1/4
16	23 1/2	1 7/16	18 1/2	21 1/4	1 1/8	16	1	5 1/4	4 1/2

Note: All dimensions are in inches and are for reference only

Navy Flange Dimensions (MIL-PRF-20042)

Normal pipe size	Bore through	Flange diameter	Flange thickness	Diameter of bolt circle	Numbers of holes	Hole diameter
1 1/2	1.77 +/- 0.003	5.06	0.44	3.94	6	0.56
2	2.24 +/- 0.003	5.56	0.44	4.44	6	0.56
2 1/2	2.75 +/- 0.004	6.13	0.5	5	6	0.56
3	3.37 +/- 0.004	6.63	0.5	5	8	0.56
4	4.37 +/- 0.004	7.69	0.56	6.56	8	0.56
5	5.42 +/- 0.004	9.06	0.56	7.81	10	0.69
6	6.46 +/- 0.004	10.13	0.56	8.88	12	0.69
8	8.41 +/- 0.004	12.38	0.63	11.06	14	0.69
10	10.48 +/- 0.004	15	0.69	13.44	15	0.81
12	12.43 +/- 0.004	17.63	0.75	16.06	18	0.81

Note: All dimensions are in inches and are for reference only

Metric Flanges and Dimensions

Note: D = flange diameter
BC = bolt circle diameter

H = bolt holes x hole diameter
1 inch = 25.4 mm

Example: D 80
BC 55
H 4 x 11

NOM DIA (mm)	DIN PN6	DIN PN10	DIN PN16	DIN PN25	DIN PN40	JIS 5K	JIS 10K	JIS 16K	JIS 20K	JIS 40K
15	80	95	95	95	95	80	95	95	95	115
	55	65	65	65	65	60	70	70	70	80
	4 x 11	4 x 14	4 x 14	4 x 14	4 x 14	4 x 12	4 x 15	4 x 15	4 x 15	4 x 19
20	90	105	105	105	105	85	105	105	105	120
	65	75	75	75	75	65	75	75	75	85
	4 x 11	4 x 14	4 x 14	4 x 14	4 x 14	4 x 12	4 x 14	4 x 14	4 x 14	4 x 19
25	100	115	115	115	115	95	125	125	125	130
	75	85	85	85	85	75	90	90	90	95
	4 x 11	4 x 14	4 x 14	4 x 14	4 x 14	4 x 12	4 x 19	4 x 19	4 x 19	4 x 19
32	120	140	140	140	140	115	135	135	135	140
	90	100	100	100	100	90	100	100	100	105
	4 x 19	4 x 18	4 x 18	4 x 18	4 x 18	4 x 15	4 x 19	4 x 19	4 x 19	4 x 19
40	130	150	150	150	150	120	140	140	140	160
	100	110	110	110	110	95	105	105	105	120
	4 x 14	4 x 18	4 x 18	4 x 18	4 x 18	4 x 15	4 x 19	4 x 19	4 x 19	4 x 23
50	140	165	165	165	165	130	155	155	155	165
	110	125	125	125	125	105	120	120	120	130
	4 x 14	4 x 18	4 x 18	4 x 18	4 x 18	4 x 15	4 x 19	8 x 19	8 x 19	8 x 19
65	160	185	185	185	185	155	175	175	175	200
	130	145	145	145	145	130	140	140	140	160
	4 x 14	4 x 18	4 x 18	4 x 18	4 x 18	4 x 15	4 x 19	8 x 19	8 x 19	8 x 23
80	190	200	200	200	200	180	185	200	200	210
	150	160	160	160	160	145	150	160	160	170
	4 x 18	8 x 18	8 x 18	8 x 18	8 x 18	4 x 19	8 x 19	8 x 23	8 x 23	8 x 23
100	210	220	220	235	235	200	210	225	225	250
	170	180	180	190	190	165	175	185	185	205
	4 x 18	8 x 18	8 x 18	8 x 22	8 x 22	8 x 19	8 x 19	8 x 23	8 x 23	8 x 25
125	240	250	250	270	270	235	250	270	270	300
	200	210	210	220	220	200	210	225	225	250
	8 x 18	8 x 18	8 x 18	8 x 26	8 x 26	8 x 19	8 x 23	8 x 25	8 x 25	8 x 27
150	265	250	250	270	270	235	250	270	270	300
	225	210	210	220	220	200	210	225	225	250
	8 x 18	8 x 22	8 x 22	8 x 26	8 x 26	8 x 19	8 x 23	12 x 25	12 x 25	12 x 33
175	395	315	315	330	350	300	305	-	-	-
	255	270	270	280	295	260	265	-	-	-
	8 x 18	8 x 22	8 x 22	12 x 26	12 x 30	8 x 23	12 x 23	-	-	-
200	320	340	340	360	375	320	330	350	350	405
	280	295	295	310	320	280	290	305	305	345
	8 x 18	8 x 22	12 x 22	12 x 26	12 x 30	8 x 23	12 x 23	12 x 25	12 x 25	12 x 33
250	375	395	405	425	450	385	400	430	430	475
	335	350	355	370	385	345	355	380	380	410
	12 x 18	12 x 22	12 x 26	12 x 30	12 x 33	12 x 23	12 x 25	12 x 27	12 x 27	12 x 33
300	440	445	460	485	515	430	445	480	480	540
	395	400	410	430	450	390	400	430	430	470
	12 x 22	12 x 22	12 x 26	16 x 30	16 x 33	12 x 23	16 x 25	16 x 27	16 x 27	16 x 39
350	490	505	520	555	580	480	490	540	540	585
	445	460	470	490	510	435	445	480	480	515
	12 x 22	16 x 22	16 x 26	16 x 33	16 x 36	12 x 25	16 x 25	16 x 33	16 x 33	16 x 39
400	540	565	580	620	660	540	560	605	605	645
	495	515	525	550	585	495	510	540	540	570
	12 x 22	16 x 26	16 x 30	16 x 36	16 x 39	16 x 25	16 x 27	16 x 33	16 x 33	16 x 39
450	595	615	640	670	755	605	620	675	-	-
	550	565	585	600	670	555	565	605	-	-
	16 x 22	20 x 26	20 x 33	20 x 36	20 x 42	16 x 25	20 x 27	20 x 33	-	-
500	645	670	715	730	795	665	675	730	-	-
	600	620	650	660	660	605	620	660	-	-
	20 x 22	20 x 26	20 x 33	20 x 36	20 x 36	20 x 25	20 x 27	20 x 33	-	-

Fraction to Decimal Conversions

Fraction	Inches	Millimeters	Fraction	Inches	Millimeters
$\frac{1}{64}$	0.015625	0.3969	$\frac{33}{64}$	0.515625	13.0969
$\frac{1}{32}$	0.03125	0.7938	$\frac{17}{32}$	0.53125	13.4938
$\frac{3}{64}$	0.046875	1.1906	$\frac{35}{64}$	0.546875	13.8907
$\frac{1}{16}$	0.0625	1.5875	$\frac{9}{16}$	0.5625	14.2876
$\frac{5}{64}$	0.078125	1.9844	$\frac{37}{64}$	0.578125	14.6844
$\frac{3}{32}$	0.09375	2.3813	$\frac{19}{32}$	0.59375	15.0813
$\frac{7}{64}$	0.109375	2.7781	$\frac{39}{64}$	0.609375	15.4782
$\frac{1}{8}$	0.125	3.175	$\frac{5}{8}$	0.625	15.8751
$\frac{9}{64}$	0.140625	3.5719	$\frac{41}{64}$	0.640625	16.2719
$\frac{5}{32}$	0.15625	3.9688	$\frac{21}{32}$	0.65625	16.6688
$\frac{11}{64}$	0.171875	4.3656	$\frac{43}{64}$	0.671875	17.0657
$\frac{3}{16}$	0.1875	4.7625	$\frac{11}{16}$	0.6875	17.4626
$\frac{13}{64}$	0.203125	5.1594	$\frac{45}{64}$	0.703125	17.8594
$\frac{7}{32}$	0.21875	5.5563	$\frac{23}{32}$	0.71875	18.2563
$\frac{15}{64}$	0.234375	5.9531	$\frac{47}{64}$	0.734375	18.6532
$\frac{1}{4}$	0.25	6.35	$\frac{3}{4}$	0.75	19.0501
$\frac{17}{64}$	0.265625	6.7469	$\frac{49}{64}$	0.765625	19.447
$\frac{9}{32}$	0.28125	7.1438	$\frac{25}{32}$	0.78125	19.8438
$\frac{19}{64}$	0.296875	7.5406	$\frac{51}{64}$	0.796875	20.2407
$\frac{5}{16}$	0.3125	7.9375	$\frac{13}{16}$	0.8125	20.6376
$\frac{21}{64}$	0.328125	8.3344	$\frac{53}{64}$	0.828125	21.0345
$\frac{11}{32}$	0.34375	8.7313	$\frac{27}{32}$	0.84375	21.4313
$\frac{23}{64}$	0.359375	9.1282	$\frac{55}{64}$	0.859375	21.8282
$\frac{3}{8}$	0.375	9.525	$\frac{7}{8}$	0.875	22.2251
$\frac{25}{64}$	0.390625	9.9219	$\frac{57}{64}$	0.890625	22.622
$\frac{13}{32}$	0.40625	10.3188	$\frac{29}{32}$	0.90625	23.0188
$\frac{27}{64}$	0.421875	10.7157	$\frac{59}{64}$	0.921875	23.4157
$\frac{7}{16}$	0.4375	11.1125	$\frac{15}{16}$	0.9375	23.8126
$\frac{29}{64}$	0.453125	11.5094	$\frac{61}{64}$	0.953125	24.2095
$\frac{15}{32}$	0.46875	11.9063	$\frac{31}{32}$	0.96875	24.6063
$\frac{31}{64}$	0.484375	12.3032	$\frac{63}{64}$	0.984375	25.0032
$\frac{1}{2}$	0.5	12.7001	1	1	25.4001

Hydrasearch Company, LLC
203A Log Canoe Circle
Stevensville, MD 21666
Phone: 410.643.8900
Fax: 410.643.8954



commercial@hydrasearch.com

www.hydrasearchcommercial.com

Catalog 619

ISO 9001

BUREAU VERITAS
Certification

